

# Tru-Trac Dual Return Tracker

## Installation Instructions



1. After identifying the problem area, prepare to install Tru-Trac Dual Return at approximately three times the width of the belt before the problem area.
2. Before removing the existing idler and brackets or V-Return frame, ensure that the Tru-Trac Dual Return will be slightly higher than the existing idlers.
3. Ensure the tracking adjustment pin is facing the catwalk to ensure ease of access once installed.
4. Set the distance between the inside of the plates to the recommended distance "C" as per the table, to obtain the correct tracking angle. Increase the distance "C" if more tracking adjustment is needed. Because the Dual Return is multi-directional, it doesn't matter which way it is installed.
5. Use slings and chain blocks to lift the Tru-Trac Dual Return into position under the conveyor belt.
6. Bolt the brackets onto the structure. Before tightening, ensure both brackets are knocked fully forwards or backward to ensure the brackets are perpendicular to the structure and lined up exactly opposite each other. Once completed tighten all bolts.
7. With the slings or chain blocks, lower the belt on to the Tru-Trac Dual Return.
8. Move the Tru-Trac Dual Return backwards and forwards with the tracking adjustment pin to check the tension. If the tension is correct, it should be difficult to move the pin backwards or forwards, this will ensure that sufficient conveyor belt tension is evenly distributed across the tracker's entire working surface.
9. If the Tru-Trac Dual Return moves easily backwards and forwards, there is insufficient tension. Loosen the base from the bracket and move it upward using the adjusting bolt. Recheck the tension. If it still insufficient, move up further until you achieve sufficient tension.
10. Installation is now complete. Start the conveyor belt to test the Dual Return.

### **Caution – Danger! Take care**

11. Test that the Tru-Trac Dual Return tracks the belt from both sides.
12. Manually de-track the belt by moving the tracking adjustment pin in one direction. When you release the pin, ...
13. ...The Tru-Trac Dual Return should automatically centre the belt. Repeat this test by moving the tracking adjustment pin in the opposite direction. If installed correctly it should centralise the belt from both sides.
14. If the Tru-Trac Dual Return remains kicked in on any one side or responds too slowly, increase the amount of tension. If the problem persists, knock existing idler brackets or frames before and after the Tru-Trac Dual Return, perpendicular and horizontally aligned to the conveyor structure.
15. Remove any other tracking devices or inverters in front of or behind the Tru-Trac Dual Return before testing the conveyor system, as they will reduce or interfere with the performance of the Tru-Trac Dual Return.
16. When installing the Tru-Trac Flat Return or Dual Return Tracker on a V- Return belt, it is necessary to install a standard flat idler prior to the Tru-Trac in order to flatten the belt and preferably one flat idler after the tracker.
17. **WARNING:** Do not invert the Tru-Trac Dual Return, without following the procedures below. The T-piece is not secured to the Base and will drop out of the base if inverted.

# Tru-Trac Dual Return Tracker

## Installation Instructions



Belt width	C (For ideal included angle = 4,5°)
1200	90
1350	92
1400	94
1500	98
1600	102
1650	104
1800	110
2000	118
2100	122
2200	126
2300	130
2400	134
2500	138

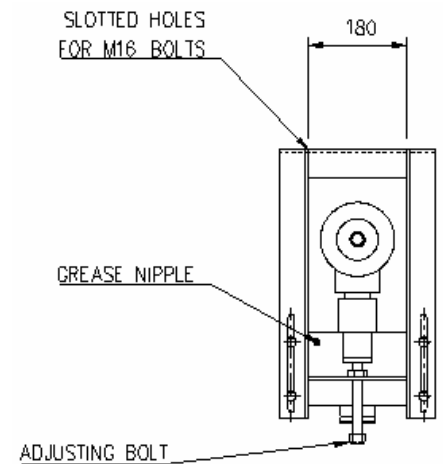
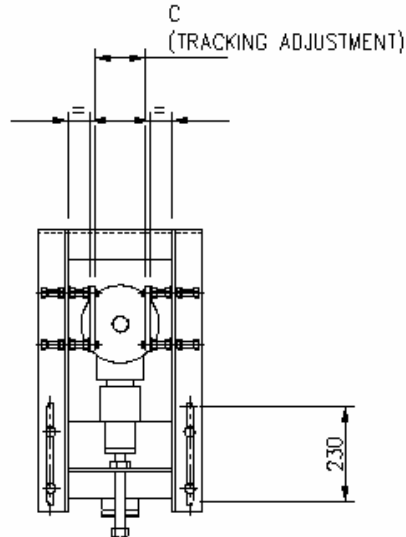

## Instructions for Inverting Tru-Trac Dual Return Tracker

This procedure is purely to prevent the T-Piece from falling out in the event of a belt break or during installation.

In order to use a Dual Return Tracker in an the inverted position

1. Remove the centre pin and roll assembly by lifting it out
2. Drill a dia 14 hole in the bottom of the of the centre bush of the dual base
3. Re-assemble the Dual,(drop T-Piece back into the centre bush), and insert M12 shoulder bolt with Loctite, ensuring that when the bolt is fully tightened onto the shoulder that it does not interfere with the free movement of the centre pin

It is advisable to seal the top of the M12 shoulder bolt with a rubber boot or suitable plastic cap to prevent any contamination in the centre bush assembly.